













<p>18 30 1 728 178 N.A.</p>  <p>100-909</p> <p>N.A.</p> <p>18 30 1 432 152</p>	<p>18 10 1 247 415 12.016</p>  <p>103-901</p> <p>103-918 x2</p> <p>BM120150</p>	<p>316i Hatchback E36 1.6 Compact 03/94 - 08/00 (1596 cc), 75 KW</p> <p>CAT</p>
<p>18 10 1 719 496 N.A.</p>  <p>100-909</p>	<p>18 10 1 705 789 12.018</p>  <p>103-901</p> <p>103-906 x2</p> <p>104-910 x2</p> <p>BM120300</p>	<p>316i Sedan E30 1.6 09/88 - 11/90 (1596 cc), 73 KW</p>
<p>11 76 1 716 470 N.A. Man.</p>  <p>100-909</p> <p>Aut.</p> <p>N.A.</p> <p>11 76 1 716 471</p>	<p>18 10 1 705 789 12.018</p>  <p>103-901</p> <p>103-906 x2</p> <p>104-910 x2</p> <p>BM120305</p>	<p>316i Sedan E30 1.6 09/88-11/90 (1596 cc), 73 KW</p> <p>CAT</p>
<p>18 30 1 728 178 N.A.</p>  <p>100-909</p> <p>N.A.</p> <p>18 30 1 432 152</p>	<p>18 10 1 737 652 12.020</p>  <p>103-904</p> <p>103-908 x2</p> <p>104-922</p> <p>BM120320</p>	<p>316i Sedan, Coupe E36 1.6 03/93 - /99 (1596 cc), 75 KW</p> <p>CAT</p>
<p>18 10 1 719 496 N.A.</p>  <p>100-909</p>	<p>18 10 1 705 789 12.018</p>  <p>103-901</p> <p>103-906 x2</p> <p>104-910 x2</p> <p>BM120350</p>	<p>316i Sedan E30 1.8 09/88 - 11/90 (1795 cc), 85 KW</p>
<p>11 76 1 716 470 N.A. Man.</p>  <p>100-909</p> <p>Aut.</p> <p>N.A.</p> <p>11 76 1 716 471</p>	<p>18 10 1 705 789 12.018</p>  <p>103-901</p> <p>103-906 x2</p> <p>104-910 x2</p> <p>BM120355</p>	<p>316i Sedan E30 1.8 09/88 - 11/90 (1795 cc), 83 KW</p> <p>CAT</p>

<p>316i Sedan E46 1.9 09/98 - 09/02 (1895 cc), 77 KW</p>	<p>CAT</p> <p>18 30 1 713 615 N.A.</p> <p>18 12 1 712 927 12.028</p> <p>100-909</p> <p>103-911 x2</p> <p>911-954</p> <p>103-920 x2</p> <p>BM120365</p>
--	--



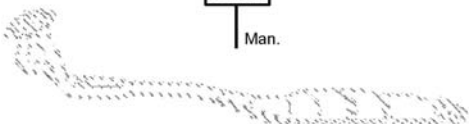







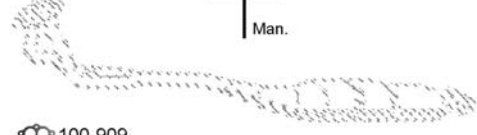

<p>316i Touring E30 1.6 /91 - 04/95 (1596 cc), 73 KW (1596 cc), 75 KW</p>	<p>CAT</p> <p>11 76 1 716 470 N.A. Man.</p> <p>18 10 1 705 789 12.018</p> <p>100-909</p> <p>103-901</p> <p>103-906 x2</p> <p>104-910 x2</p> <p>Aut. N.A.</p> <p>11 76 1 716 471</p> <p>BM120400</p>
---	--

<p>316i Touring E36 1.6 01/96 - 10/99 (1596 cc), 75 KW</p>	<p>CAT</p> <p>18 30 1 432 152 N.A.</p> <p>18 10 1 737 652 12.020</p> <p>100-909</p> <p>103-904</p> <p>103-908 x2</p> <p>104-922</p> <p>BM120405</p>
--	---

<p>318i Sedan E30 1.8 09/87 - 11/90 (1795 cc), 85 KW</p>	<p>18 10 1 712 790 N.A.</p> <p>18 11 1 719 202 12.021</p> <p>100-909</p> <p>103-901</p> <p>103-906 x2</p> <p>104-911 x2</p> <p>BM120475</p>
--	---

<p>318i Sedan E30 1.8 09/87 - 08/91 (1795 cc), 83 KW</p>	<p>CAT</p> <p>11 76 1 716 470 N.A. Man.</p> <p>18 11 1 719 202 12.021</p> <p>100-909</p> <p>103-901</p> <p>103-906 x2</p> <p>104-911 x2</p> <p>Aut. N.A.</p> <p>11 76 1 716 471</p> <p>BM120480</p>
--	--

<p>318i Sedan E36 1.8 12/90 - 02/93 (1796 cc), 83 KW</p>	<p>18 10 1 723 750 N.A.</p> <p>18 10 1 247 278 12.034</p> <p>100-909</p> <p>103-904</p> <p>104-922</p> <p>103-908 x2</p> <p>BM120490</p>
--	--

<p>18 30 1 728 178</p> <p>N.A.</p>  <p>100-909</p> <p>N.A.</p> <p>18 30 1 432 152</p>	<p>18 10 1 247 278</p> <p>12.034</p>  <p>103-904</p> <p>104-922</p> <p>103-908 x2</p> <p>BM120495</p>	<p>318i Sedan E36 1.8 12/90 - /98 1796 cc, 83 KW 1796 cc, 85 KW</p> <p>CAT</p>
<p>18 30 1 713 615</p> <p>N.A.</p>  <p>100-909</p> <p>103-911 x2</p> <p>18 30 1 432 152</p>	<p>18 12 1 712 927</p> <p>12.028</p>  <p>911-954</p> <p>103-920 x2</p> <p>BM120510</p>	<p>318i Sedan, Coupe E46 1.9 02/98 - 09/01 (1895 cc), 87 KW</p> <p>CAT</p>
<p>11 76 1 716 470</p> <p>N.A. Man.</p>  <p>100-909</p> <p>Aut.</p> <p>N.A.</p> <p>11 76 1 716 471</p>	<p>18 11 1 719 202</p> <p>12.021</p>  <p>103-901</p> <p>103-906 x2</p> <p>104-911 x2</p> <p>BM120565</p>	<p>318i Cabrio E30 1.8 09/90 - 11/93 (1795 cc), 83 KW</p> <p>CAT</p>
<p>18 30 1 728 178</p> <p>N.A.</p>  <p>100-909</p> <p>N.A.</p> <p>18 30 1 432 152</p>	<p>18 10 1 247 278</p> <p>12.034</p>  <p>103-904</p> <p>104-922</p> <p>103-908 x2</p> <p>BM120570</p>	<p>318i Cabrio E36 1.8i 11/93 - /00 (1796 cc), 85 KW</p> <p>CAT</p>
<p>18 10 1 712 790</p> <p>N.A.</p>  <p>100-909</p> <p>18 10 1 432 152</p>	<p>18 11 1 719 202</p> <p>12.021</p>  <p>103-901</p> <p>103-906 x2</p> <p>104-911 x2</p> <p>BM120600</p>	<p>318i Touring E30 1.8 /89 - 04/95 (1795 cc), 85 KW</p> <p>CAT</p>
<p>11 76 1 716 470</p> <p>N.A.</p>  <p>100-909</p> <p>N.A.</p> <p>11 76 1 716 471</p>	<p>18 11 1 719 202</p> <p>12.021</p>  <p>103-901</p> <p>103-906 x2</p> <p>104-911 x2</p> <p>BM120605</p>	<p>318i Touring E30 1.8 09/90 - 04/95 (1795 cc), 83 KW</p> <p>CAT</p>

318i
Touring
E36
1.8i
01/95 - 12/99
(1796 cc), 85 KW

CAT

18 30 1 728 178 **N.A.** 18 10 1 247 278 **12.034**

100-909 103-904 104-922
103-908 x2

N.A.

BM120610 18 30 1 432 152

318
Sedan
E36
1.7 TDS Turbo
Diesel
/94 - /98
(1665 cc), 66 KW

CAT

18 31 2 245 553 **N.A.** 18 31 2 245 552 **N.A.** 18 10 2 245 524 **12.022**

911-954 103-904 103-909 x2

BM120700

318
Touring
E36
1.7 TDS Turbo
Diesel
05/95 - /99
(1665 cc), 66 KW

CAT

18 31 2 245 553 **N.A.** 18 31 2 245 552 **N.A.** 18 10 2 245 524 **12.022**

911-954 103-904 103-909 x2

BM120750

320i
Sedan
E30
2.0
10/82 - 11/90
(1990 cc), 92 KW

N.A. **N.A.** **12.007** ▲ **12.006**

18 11 1 177 661 10/82-08/83 18 11 1 178 021 09/83-11/90 18 12 1 177 945 09/83-11/90 18 10 1 719 234

100-902 102-902 911-954 103-906 x2
101-942 102-942 104-907 -09/85 104-910 x2 09/85-

N.A. **N.A.** **N.A.**

BM120805 18 11 1 177 663 18 11 1 178 023 18 12 1 176 985

320i
Sedan
E30
2.0
10/82 - 11/90
(1990 cc), 92 KW

N.A. **12.007** ▲ **12.006**

18 11 1 177 950 09/83-09/86 18 12 1 177 945 09/83-09/86 18 10 1 719 234

100-901 102-902 911-954 103-906 x2
102-942 101-942 104-907 -09/85 104-910 x2 09/85-

N.A. **N.A.**

BM120810 18 11 1 177 153 18 12 1 176 985

320i
Sedan
E30
2.0
09/86 - 11/90
(1990 cc), 95 KW

CAT

11 76 1 716 743 **N.A.** 18 10 7 105 788 **12.023**

100-906 x2 102-942 103-901 103-906 x2
101-945 104-911 x2

BM120815

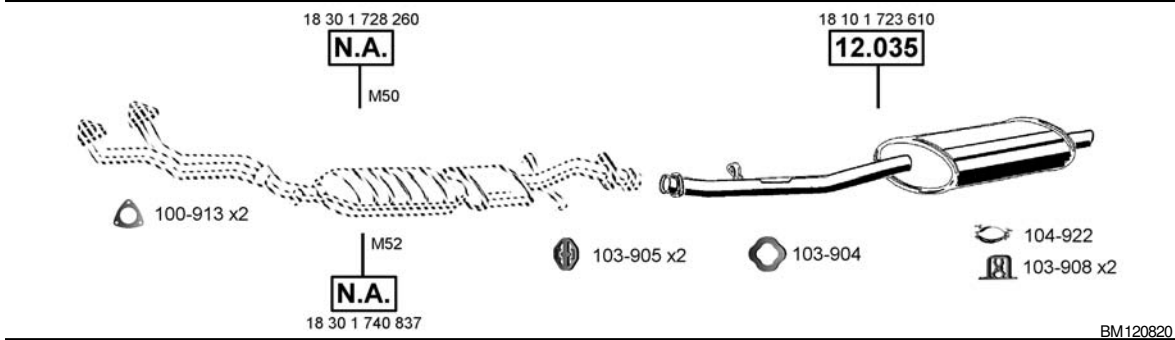

320i
Sedan, Coupe
E36
2.0 - 24V
12/90 - /99
(1991 cc), 110 KW

CAT

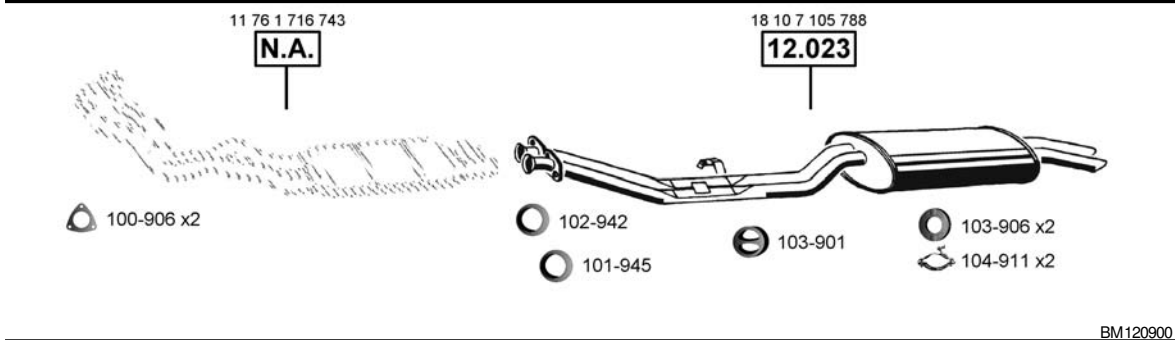

320i
Cabrio
E30
2.0
09/86 - /93
(1990 cc), 95 KW

CAT

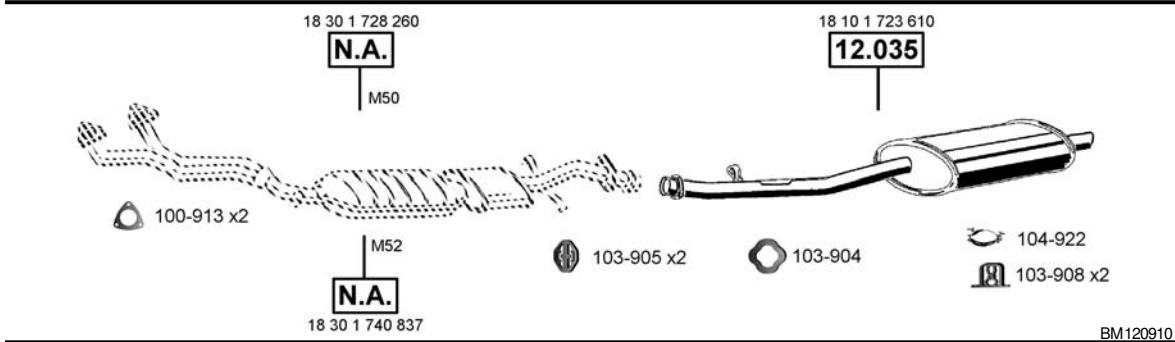

320i
Cabrio
E36
2.0
/93 - 12/99
1991 cc, 110 KW

CAT

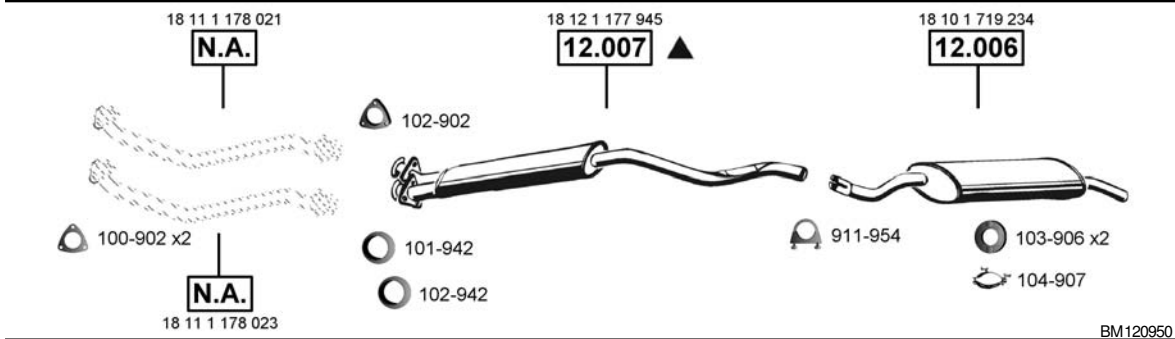

320i
Touring
E30
2.0
04/88 - 12/91
(1990 cc), 95 KW

CAT

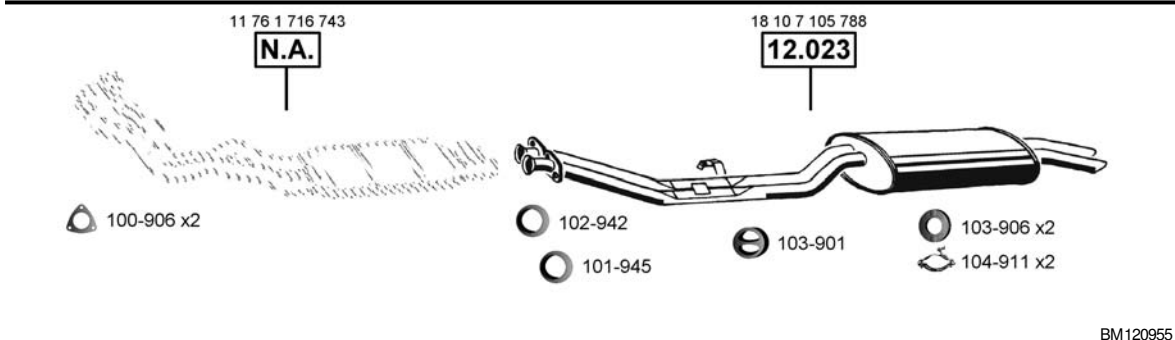

320i
Touring
E30
2.0
04/88 - 12/91
(1990 cc), 95 KW

CAT

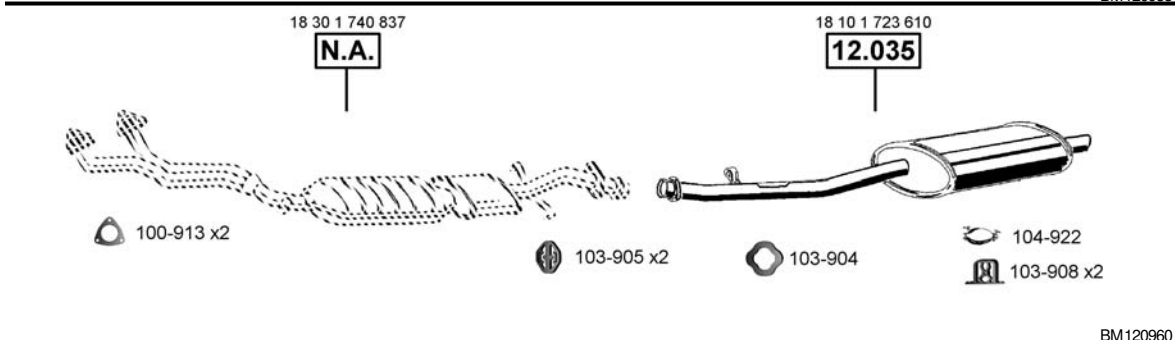

320i
Touring
E36
2.0
01/95 - /99
(1991 cc), 110 KW

CAT

323i
Sedan, Coupe
E36
2.5
01/94 - /99
(2494 cc), 125 KW

CAT

18 30 1 740 837
N.A.

18 10 1 723 610
12.035

100-913 x2

103-905 x2

103-904

104-922

103-908 x2

BM121100

323i
Cabrio
E36
2.5
01/95 - 12/99
(2494 cc), 125 KW

CAT

18 30 1 740 837
N.A.

18 10 1 723 610
12.035

100-913 x2

103-905 x2

103-904

104-922

103-908 x2

BM121200

323i
Touring
E36
2.5
01/95 - 12/99
(2494 cc), 125 KW

CAT

18 30 1 740 837
N.A.

18 10 1 723 610
12.035

100-913 x2

103-905 x2

103-904

104-922

103-908 x2

BM121250

324
Sedan
E30
2.4 Diesel
10/85 - 07/87
(2443 cc), 63 KW

18 11 1 178 075
N.A.

18 12 1 177 945
12.007 ▲

18 10 1 719 234
12.006

100-904 x2

102-942

101-942

911-954

103-906 x2

104-910 x2

18 11 1 178 077
N.A.

BM121350

324
Sedan
E30
2.4 Diesel
08/87 - 11/90
(2443 cc), 63 KW

18 11 1 178 075
N.A.

18 12 1 177 945
12.007 ▲

18 11 1 177 001
0B.004

18 10 2 242 267
N.A.

100-904 x2

102-942

101-942

911-954 x2

103-906

104-910

18 11 1 178 077
N.A.

BM121355

325i
Sedan
E30
2.5
/85 - 11/90
(2494 cc), 126 KW

CAT

11 76 1 716 743
N.A.

18 10 7 105 788
12.023

100-906 x2

102-942













101-945

103-901

103-906 x2

104-911 x2

BM121405

<p>11 76 1 716 743 N.A.</p>  <p>100-906 x2</p>	<p>18 10 7 105 788 12.023</p>  <p>102-942 101-945 103-901 103-906 x2 104-911 x2</p>	<p>325i Cabrio E30 2.5 /85 - 02/93 (2494 cc), 126 KW</p> <p style="text-align: right;">CAT</p>
<p>11 76 1 716 743 N.A.</p>  <p>100-906 x2</p>	<p>18 10 7 105 788 12.023</p>  <p>102-942 101-945 103-901 103-906 x2 104-911 x2</p>	<p>325i Touring E30 2.5 /87 - /93 (2494 cc), 126 KW</p> <p style="text-align: right;">CAT</p>
<p>11 76 1 716 743 N.A.</p>  <p>100-906 x2</p>	<p>18 10 7 105 788 12.023</p>  <p>102-942 101-945 103-901 103-906 x2 104-911 x2</p>	<p>325e Sedan E30 2.7 12/86 - /88 (2693 cc), 95 KW</p> <p style="text-align: right;">CAT</p>
<p>11 76 1 716 748 N.A.</p>  <p>100-906 x2</p>	<p>18 10 7 105 788 12.023</p>  <p>102-942 101-945 103-901 103-906 x2 104-911 x2</p>	<p>325iX Sedan E30 2.5 4X4 09/87 - 11/90 (2494 cc), 126 KW</p> <p style="text-align: right;">CAT</p>
<p>11 76 1 716 748 N.A.</p>  <p>100-906 x2</p>	<p>18 10 7 105 788 12.023</p>  <p>102-942 101-945 103-901 103-906 x2 104-911 x2</p>	<p>325iX Touring E30 2.5 4X4 /88 - /93 (2494 cc), 126 KW</p> <p style="text-align: right;">CAT</p>
<p>18 31 2 244 490 N.A.</p> <p>18 10 2 244 206 N.A.</p>  <p>101-959 115-901 x2 102-958</p>	<p>18 10 2 244 207 12.024</p>  <p>911-965 103-904 103-909 x2</p>	<p>325 Sedan E36 2.5 TD, TDS Turbo Diesel 12/90 - 12/98 (2498 cc), 85 KW (2498 cc), 105 KW</p> <p style="text-align: right;">CAT</p>

325 Sedan E36 2.5 TDS Turbo Diesel 12/95 - 12/98 (2498 cc), 85 KW (2498 cc), 105 KW	CAT 18 31 2 246 455 N.A.	18 30 2 246 460 N.A.	18 21 2 246 457 12.017

BM121610

325 Touring E36 2.5 TDS Turbo Diesel 01/94 - 12/99 (2498 cc), 85 KW (2498 cc), 105 KW	18 31 2 244 490 N.A.	18 10 2 244 206 N.A.	18 10 2 244 207 12.024

BM121630

325 Touring E36 2.5 TDS Turbo Diesel 12/95 - 12/99 (2498 cc), 85 KW (2498 cc), 105 KW	CAT 18 31 2 246 455 N.A.	18 30 2 246 460 N.A.	18 21 2 246 457 12.017

BM121640

520i Sedan E28 2.0 /81 - 06/88 (1990 cc), 95 KW	18 11 1 176 058 N.A.	18 12 1 175 748 N.A.	18 12 1 175 746 N.A.	18 12 1 175 747 12.011











BM121850



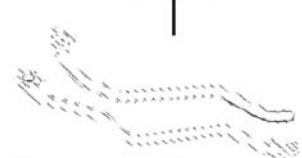

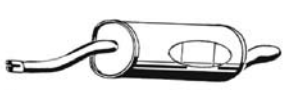
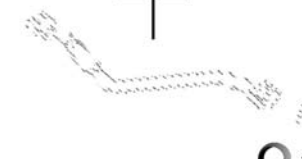
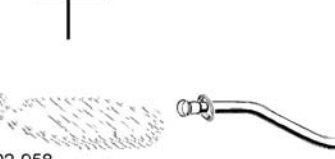

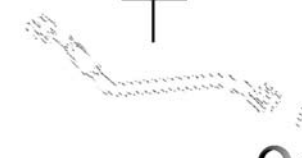
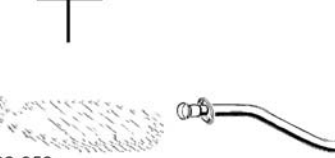

























520i Sedan E34 2.0 - 24V 09/90 - 08/95 (1991 cc), 110 KW	18 30 1 728 038 N.A.	18 12 1 723 507 N.A.	18 12 1 723 508 12.033

BM121865

520i Touring E34 2.0 - 24V 11/91 - 03/97 (1991 cc), 110 KW	18 30 1 728 038 N.A.	18 12 1 723 507 N.A.	18 12 1 723 508 12.033

BM121950

<p>18 11 1 175 606 N.A.</p>  <p>100-902 x2 N.A.</p> <p>18 11 1 175 604</p>	<p>18 12 1 175 748 N.A.</p>  <p>102-902</p> <p>101-942 102-942</p>	<p>18 12 1 175 746 N.A.</p>  <p>911-948 x2</p> <p>103-901 x2</p>	<p>18 12 1 175 747 12.011</p>  <p>911-960</p> <p>103-906 104-905</p> <p>525i Sedan E28 2.5 /81 - 06/88 (2494 cc), 110 KW</p> <p>BM122100</p>
<p>18 11 1 176 058 N.A.</p>  <p>100-902 x2 N.A.</p> <p>18 11 1 175 575</p>	<p>18 12 1 175 748 N.A.</p>  <p>102-902</p> <p>101-942 102-942</p>	<p>18 12 1 175 746 N.A.</p>  <p>911-948 x2</p> <p>103-901 x2</p>	<p>18 12 1 175 747 12.011</p>  <p>911-960</p> <p>103-906 104-905</p> <p>525E Sedan E28 2.7 /83 - /88 (2693 cc), 95 KW</p> <p>BM122200</p>
<p>18 11 2 244 592 N.A.</p> 	<p>18 31 2 245 409 N.A.</p>  <p>102-958</p>	<p>18 10 2 243 970 12.029</p>  <p>103-901</p> <p>103-906 104-914</p>	<p>525 Sedan E34 TD, TDS Turbo Diesel 01/92 - 12/96 (2498 cc), 85 KW (2498 cc), 105 KW</p> <p>CAT</p> <p>BM122300</p>
<p>18 11 2 244 592 N.A.</p> 	<p>18 31 2 245 409 N.A.</p>  <p>102-958</p>	<p>18 10 2 243 970 12.029</p>  <p>103-901</p> <p>103-906 104-914</p>	<p>525 Touring E34 2.5 TD, TDS Turbo Diesel 09/92 - 12/96 (2498 cc), 85 KW (2498 cc), 105 KW</p> <p>CAT</p> <p>BM122400</p>

100-901		316 (/75-10/82), 318 (/75-10/82), 320 (/75-10/77), 320i (/75-11/90), 518 (/81-09/83)	103-911		316i (09/98-09/02), 318i (02/98-09/01)
100-902		320i (10/82-12/91), 520i (/81-06/88), 525i (/81-06/88), 525E (/83-/88)	103-918		316i (/94-/99)
100-904		324 (10/85-11/90), 325i (/85-11/90), 325iX (09/87-11/90), 524 (/86-/89)	103-920		316i (09/98-09/02), 318i (02/98-09/01)
100-906		320i (04/86-/93), 325i (/85-02/93), 325e (12/86-/88), 325iX (09/87-/99), 520i (01/88-09/90)	104-905		520i (/81-06/88), 524 (/83-/89), 525i (/81-06/88), 525E (/83-/88)
100-909		316i (09/88-09/02), 318i (09/87-09/01)	104-907		320i (10/82-12/91)
100-913		320i (12/90-12/99), 323i (01/94-12/99), 520i (09/90-03/97)	104-910		316i (09/88-04/95), 320i (10/82-11/90), 324 (10/85-11/90)
101-942		320i (10/82-12/91), 324 (10/85-11/90), 520i (/81-06/88), 524 (/86-/89), 525i (/81-06/88), 525E (/83-/88)	104-911		318i (09/87-04/95), 320i (09/86-/93), 325i (/85-02/93), 325e (12/86-/88), 325iX (09/87-/93)
101-945		320i (09/86-/93), 325i (/85-02/93), 325e (12/86-/88), 325iX (09/87-/93), 520i (01/88-03/97)	104-914		520i (01/88-09/90), 525 (01/92-03/96)
101-959		325 (12/90-/99)	104-915		520i (09/90-03/97)
102-902		320i (10/82-12/91), 520i (/81-06/88), 524 (/86-/89), 525i (/81-06/88), 525E (/83-/88)	104-922		316i (12/90-10/99)
102-942		315 (/80-/84), 316 (/75-10/82), 318 (/75-10/82), 320 (/75-/93), 324 (10/85-11/90), 325i (/85-02/93), 325e (12/86-/88), 325iX (09/87-/93),	115-901		325 (12/90-/99)
102-958		325 (12/90-/99), 524 (/83-03/88), 525 (01/92-03/96)	911-948		520i (/81-06/88), 525i (/81-06/88), 525E (/83-/88)
103-901		316i (09/88-/99), 318i (09/87-04/95), 320i (09/86-12/91), 325i (/85-02/93), 325e (12/86-/88), 325iX (09/87-/93), 520i (/81-03/97), 524 (/83-/89),	911-954		316i (09/98-09/02), 318 (/94-/99), 318i (02/98-09/01), 320i (10/82-12/91), 324 (10/85-11/90)
103-904		316i (12/90-10/99), 318 (/94-/99), 318i (12/90-12/99), 320i (12/90-/99), 323i (01/94-12/99), 325 (12/90-/99)	911-960		520i (/81-09/90), 524 (/86-/89), 525i (/81-06/88), 525E (/83-/88)
103-905		320i (12/90-12/99), 323i (01/94-12/99)	911-965		325 (12/90-/99), 520i (09/90-03/97), 524 (/83-03/88)
103-906		316 (10/82-/90), 316i (09/88-04/95), 318i (10/82-04/95), 320i (10/82-/93), 324 (10/85-11/90), 325 (12/90-12/95), 325i (/85-02/93), 325e (12/86-/88)			
103-908		316i (12/90-10/99), 318i (12/90-12/99), 320i (12/90-12/99), 323i (01/94-12/99)			
103-909		318 (/94-/99), 325 (12/90-/99)			

0B.004	911-954 2x
12.006	103-906 2x, 104-907, 104-910 2x, 911-954
12.011	103-906, 104-905, 911-960
12.016	103-901, 103-918 2x
12.017	103-904, 103-909 2x, 911-965
12.018	103-901, 103-906 2x, 104-910 2x
12.020	103-904, 103-908 2x, 104-922
12.021	103-901, 103-906 2x, 104-911 2x
12.022	103-904, 103-909 2x
12.023	101-945, 102-942, 103-901, 103-906 2x, 104-911 2x
12.024	103-904, 103-909 2x, 911-965
12.028	103-920 2x, 911-954
12.029	103-901, 103-906, 104-914
12.033	103-906 2x, 104-915 2x, 911-965
12.034	103-904, 103-908 2x, 104-922
12.035	103-904, 103-908 2x, 104-922
